

RS160D PMDC Servo Controller



Robot-Solutions, LLC

Table of Contents

Specifications	1
Overview	2
Factory Default	3
<i>Customization</i>	4
<i>Channel Mixing (x)</i>	5
<i>Input Control Curve (C)</i>	5
<i>Variable Brake (B)</i>	5
<i>R/C input dead band (i)</i>	5
<i>Minimum Drive (M)</i>	6
<i>Power Slew Rate (s)</i>	6
<i>R/C input calibration</i>	6
<i>Saving custom settings (w)</i>	7
User Interface	8
Internal Register Summary	9
Internal Register Description	12
<i>Brake (B)</i>	12
<i>Baud Rate (b)</i>	12
<i>R/C Input Curve (C)</i>	12
<i>Copy Parameters (c)</i>	12
<i>Derivative (velocity) Gain (D)</i>	12
<i>Error Dead Band (d)</i>	13
<i>Back-EMF Factor (E)</i>	13
<i>Encoder value (e)</i>	13
<i>Input Factor (F)</i>	13
<i>Temperature Protection Override (f)</i>	14
<i>Integral Gain (I)</i>	14
<i>R/C Input Dead Band (i)</i>	14
<i>Feedback Select (J)</i>	14
<i>Control Input Select (j)</i>	14
<i>Local Echo Option (l)</i>	15
<i>Minimum Drive (M)</i>	16
<i>Servo Mode (m)</i>	16
<i>R/C Pulse High Limit (N)</i>	16
<i>R/C Pulse Low Limit (n)</i>	17
<i>Proportional (Position) Gain (P)</i>	17
<i>Position Set Point (p)</i>	17
<i>Factory Preset (Q)</i>	17
<i>Servo Update Rate (r)</i>	18
<i>Power Slew Rate (s)</i>	18
<i>Torque Limit (T)</i>	18
<i>Torque Set point (t)</i>	18

<i>Unit Amount Minimum Move (U)</i>	19
<i>Unit Amount Manual Move (u)</i>	19
<i>Velocity Limit (V)</i>	19
<i>Velocity Set point (v)</i>	19
<i>Write User Memory (w)</i>	19
<i>Channel Mixing (x)</i>	20
Menu Items	20
Output Drive values	21
Control Period	21
Position & Encoder values	21
Velocity	21
Torque	21
Tuning, discovering servo PID Gain values	22
<i>Off Mode (0):</i>	22
<i>PWM Mode (1):</i>	22
<i>Torque Mode (2):</i>	22
<i>Velocity Mode (3):</i>	22
<i>Position Mode (4):</i>	23
Indicators and Outputs	23
<i>Status LED</i>	23
<i>Temp LED</i>	23
<i>COAST LED (Aux, Left & Right)</i>	23
<i>FWD/REV LED (Aux, Left, Right)</i>	23
Limitations and Warrantees	24
Support	24
General Guidelines	24
Appendix A: System Software Updates	25
Appendix B: Input methods	26
<i>Control Input Methods</i>	26
Serial	26
R/C control	26
Analog Signal	26
Step & Direction	26
<i>Feedback Input Methods</i>	27
Encoder	27
Analog Signal	27
Appendix C: Interface Wiring Information	28
<i>Analog</i>	28
<i>Step & Direction</i>	29
<i>Incremental Encoder</i>	30
<i>Manual Move</i>	31
Appendix D: Example applications	32

<i>Factory Default</i>	32
<i>Giant R/C Servo</i>	33
Set Up & Tuning.....	33
<i>CNC (Stepper motor) servo</i>	35

Specifications

The RS160D servo uses custom software to implement a 2.5 channel high-powered servo system. The servo uses a quadrature encoder feedback mechanism to control torque, velocity, and position of the output.

- Enclosure size: 8.80" x 4.80" x 2.40" 3.40" high including fan
- Weight with enclosure: 2.5 lb.
- Three 5 pin finger latching encoder inputs.
- Dual main channels 160 Amps each
- Current limiting on both main channels.
- Thermal protection.
- Connector for external power driver module for third channel operation.
- 4-42v battery operation¹.
- Large power connector accepts up to 0 AWG wires.
- Full RS232 serial command and setup.
- Standard RS232 communications N81- 4800,9600,19200 or 38400 baud.
- Serial boot loader for future RS232 servo software updates (no special programming hardware required). See appendix A.
- Multiple-operating modes:
 - Off
 - Normal PWM
 - Torque
 - Velocity
 - Servo-Winch-Position
 - Servo-Position
- Thermal power monitoring and limiting.
- Manual control inputs (Up/Down) for each channel (Left, Right and Aux) to facilitate rigging (DB9M). See Appendix B.
- User selected control inputs: Serial Command, Analog Voltage, R/C Pulse or Step & Direction (CNC).
- User selected servo feedback: Encoder or Analog Voltage
- User adjusted hardware current limiting (Potentiometer adjustment).
- User adjustable software current limiting (Torque limit).
- Robust signal processing for smooth, reliable fail-safe operation.
- Indicator LED's show direction, power, over-temperature, and board status.

¹ If the main battery voltage is over 36V nominal, jumper J7 must be moved to the HV position and a second battery for the logic supply must be connected to the HV SUPPLY connector. The HV supply can range from 4V to 36V.

Note the GND terminal on the logic supply and the GND terminal on the main power connector are tied together. If tapping off of the center of a multiple series battery for the logic supply, do not provide a second ground to the logic connector.

Overview

The RS160D brushed Motor Controller provides a flexible platform for controlling brushed DC motors. The controller has two power drivers built in and a standard OSMC connector for a third power driver.

The default factory configuration supports operation with R/C radios for traditional combat and remote control robotics applications. The factory default is easily modified and stored in non-volatile (configuration) memory and restored whenever power is applied. In factory default mode the Left R/C channel controls forward reverse motion and the Right channel controls steering.

All configuration and control parameters are set via serial menus and configuration strings. The serial interface supports standard RS232 signaling from 4800 to 38,400 baud using a normal DB9 cable. The entire unit may be configured and controlled via a PC or Laptop using a terminal emulator (e.g. Hyperterm).

The RS160D supports a variety of servo operation modes (position, velocity, torque & power) using a variety of input and feedback methods. The RS160D accepts the following control input signals: serial commands, Analog voltage (0-5v), Radio Control signaling or Step & direction. For servo feedback the RS160D accepts either analog voltages (0-5v potentiometer) or quadrature encoders. Inexpensive industrial encoders can be obtained from www.usdigital.com and the RS160D includes sockets compatible with US Digital 5 pin finger latching cabling. The relationship between the various control inputs output are set by serial configuration commands and the serial interface is always available for adjusting parameters regardless of the operating mode.

Some examples of systems possible with the RS160D

1. A large R/C style servo can be created by combining the R/C control input with the analog voltage feedback.
2. Using R/C input and encoders enables velocity control which is superior for handling of remote control robots.
3. Serial input with encoder feedback enables machine controllable subsystems, such as steering or brake controllers in large vehicles.
4. Step & Direction input with encoder feedback simulates large high powered step motors with inexpensive PMDC motors. The step & direction interfaces directly with CNC software.

The RS160D can store up to four unique sets of configuration data. The Controller automatically loads the last saved or recalled set upon power up, supporting unattended operation.

Factory Default

As shipped from the factory the RS160D firmware will boot into a default minimal function mode. The feature set is as follows:

1. Basic PWM control: 95%² reverse to 95% forward power.
2. R/C input control, +/- 10us dead band.
3. Dual stick (no channel mixing).
4. Normal R/C calibration.
5. Mild input curve.
6. 100% brake with neutral command
7. .1 second power slew rate
8. Serial communications set at 38,400 baud.

At any time the user can reset the unit to the factory values with a simple command via the terminal interface. The RS160D uses a standard DB9 RS232 cable and should connect to any PC or laptop computer. Newer computers may only have USB connectors and an inexpensive USB to Serial adapter may be used. Connect a terminal emulator (Hyperterm) with the following settings:

- 38400 baud
- 8 bit no parity
- One stop bit

At the prompt type in the following characters:

@0sQ0<cr> (<cr> represents the ENTER key.)

If you desire single stick control type in the following string instead:

@0sQ1<cr>

NOTE: default values are not stored in non-volatile memory by default. You need to write the values out before they “stick”. The command to do this is:

@0sw0<cr>

The non-volatile store and how to use it is described in a later section.

² For reasons related to the hardware current limiting logic 100% power is not allowed.

Customization

There are a variety of customizations that can be applied to the RS160D:

1. Channel Mixing for single or dual stick operation
2. Calibration of R/C inputs
3. Adjustable control curves
4. Control Dead band
5. Minimum Drive values for output
6. Variable braking when neutral
7. Variable power slew rate
8. Up to four different sets of customizations may be stored and recalled.

What follows are customizations that apply to the default factory configuration. These registers are described in detail in this section and primarily apply to simple R/C control of power – a typical remote control robot configuration. There is a complete description of all customization registers further on in this document under **Internal Register Description**.

In general, configuration parameters are entered in the following form:

@{channel}{s,g,a}{register}{value}

Each command starts with the @ character. The second character is a number indicating which channel. The channels are numbered as follows:

0	Left	R/C input or Power output
1	Right	R/C input or Power output
2	Aux	R/C input or Power output
3	Flip	R/C input only

The third character indicates the operation:

s = set the value into the register
g = Get the value stored in non-volatile memory
a = Get the actual current operating value

Note: for some commands the programmed value is not acted upon until the system is reset, hence the 'a' modifier.

The fourth character is the "register" that contains the value being adjusted

The final field is a signed decimal number (i.e. it can be negative). If this number is left out a '0' will be used instead.

All commands are terminated with a Carriage return (enter) <cr>.

A typical command might be “Set Left Channel Drive 250” and would look like this:

@0sd250

The command to read the drive for the Left Channel and print it out would look like this:

@0gd

Channel Mixing (x)

Channel mixing is a global value not associated with R/C input channels or PWM output channels. The “channel” value is ignored. The *value* can be either 0 (Tank) or 1 (Mixed). Mixing uses the **Left** channel as throttle and mixes in the **Right** channel as steering. This is commonly used to implement *single stick control* for steering & throttle in remote control robots.

@0sx0 – Disable Mixing

@0sx1 – Enable Mixing

Input Control Curve (C)

A variable exponential control curve can be applied to the R/C input. The curve value applies to all channels. The amount ranges from 0, which is flat, to 7, which represents a fairly aggressive curve.

@0sC{0-7}

The factory default is a mild curve of 3.

Variable Brake (B)

When control sticks are in neutral position the RS160D can apply a variable amount of braking effort. Braking varies from 0 (coasting) to 31 (100%). Braking is regenerative and will generate current and re-charge the supply battery. The string to set the brake amount:

@{0, 1 or 2},sB{0-31}

Braking is specified independently for the Left, Right or Aux channels, hence the 0, 1 or 2 in the first field.

The Factory default is 100% brake

R/C input dead band (i)

Specifying the R/C input dead band can help prevent jitter when control sticks are in neutral position. The dead band is specified in +/- microseconds.

@{0, 1, 2, or 3}si{0-63}

Factory default value is +/- 10 microseconds.

Minimum Drive (M)

Often robotic drive systems have significant friction to overcome before the robot moves. Minimum drive helps compensate for that by boosting the PWM values.

@{0, 1, 2}sM{0-255}

Note: 10-25 are normal values

The best way to set this parameter is to use the serial interface to display drive values and move the trim/stick until the drive train just starts to move; then record the values and use that as a starting point.

Factory default is 0.

Power Slew Rate (s)

For high power systems suddenly changing power levels can introduce shock and or large current draws. The former is hard on the mechanical system and the latter can cause trouble with batteries. The RS160D has a variable power slew function that is only active in PWM mode. The slew function specifies the time, in 1/10th second units; it takes to move the output power from -100% to +100% (full reverse to full forward). Too much slew can make the operation sluggish. For large kinetic energy weapons, however, a large slew is needed to limit the inrush or regenerative braking currents as the device accelerates or decelerates.

@{0, 1, or 2}sS{0-100}

Note: a typical value is 0 to 10 for drive outputs.

The factory default is 1.

Note: Proper slew rate operation depends upon the default internal update rate of 50 Hz and works only in the default PWM mode. Please do not modify the update rate if you use this function. If you do modify the update rate be aware that the slew values will need to be scaled appropriately.

R/C input calibration

The RS160D can be calibrated for the particular range of R/C pulse widths supplied by the radio. Calibration can be done explicitly, where the user specifies the minimum and maximum control pulse widths in microseconds, or calibration can be done by discovery. In discovery mode the control sticks are moved to their extremes, and the software records the minimum and maximum values.

There are two ways to enter and exit **discovery calibration** mode:

1. Press and hold the CAL button for more than 3 seconds.
2. Type in "Cal<cr>" on the serial port.

Calibration mode is indicated by a 1 second periodic “wink” and a text message is printed to the serial port. To exit calibration mode do one of the following:

1. Press and hold the CAL button for more than 3 seconds
2. Type in an ESC character on the serial interface

Exit mode is indicated by the status LED returning to its previous flash pattern and a short message printed to the serial interface.

NOTE: Once calibrated, the values need to be saved in one of the user configuration slots or they will be lost the next time the controller is powered.

Factory default values for all channels:

Minimum: 1.095 milliseconds
Maximum: 1.950 milliseconds

Although the allowable range is anywhere from 0 to 32 milliseconds, the controller will only recognize pulse width values between 0.850 and 2.150 milliseconds long. The recognized values are relaxed enough for all known R/C pulse gear including IFI robot controllers.

Saving custom settings (w)

All settings and calibration is performed on the running system. When power is removed, the current values are lost. The RS160D provides four non-volatile memory slots for storing parameters. Four sets can be stored and the RS160D will restore the last accessed slot whenever rebooting. Settings and calibrations are stored with the following command string:

@{0, 1, 2 or 3}sw

When power is lost and restored, the RS160D will restore the last slot stored. If an alternate slot is needed it can be recalled with the following command:

@{0, 1, 2 or 3}gw

After recall, if the power is lost, the RS160D will restore the last recalled or stored slot.

User Interface

The host controller communicates through a standard DB9F RS232 serial port, compatible with standard computers. In addition to entering in data in command packets, the RS232 port supports basic line editing with the backspace key. The control interface also has a simple menu system that allows immediate feedback about servo performance.

Below is representative of the text printed to the serial port at power on. It includes many of the commands and settings available. Please refer to appendix A for a complete list of parameters.

```
RS160D-AGU
p<cr>           Parameters
r<cr>           Reset Servo (E-Stop)
a{#}<cr>        Analog, # = Repetition Rate in responses per second
d{#}<cr>        Drive
e{#}<cr>        Encoder
S{#}<cr>        Streamlined Parameters
t{#}<cr>        Temp
v{#}<cr>        Velocity
@<adx><mod><reg><val>  Command Packet<cr>
  <adx> 0 (left), 1 (right), 2 (aux)
  <mod> s (set), a (actual), c (current)
  <val> Decimal number (default = 0)
  <reg> m: 0=off, 1=pwm, 2=torq, 3=vel, 4=Winch, 5=Position, 6=Alt
  M: Minimum Drive value to move output. (Default=0)
  d: Position Error Deadband (Default =255)
  f: Thermal protection on=1/off=0 (volatile, can't be stored)
  p: Position Setpoint
  u: Unit amount (for manual move)
  U: Unit amount filter
  r: Loop Rate (0-255)
  t: Torque Setpoint (+/-255)
  T: Torque Limit (0-255)
  v: Velocity Set point
  V: Velocity Limit
  w: Write values to EEPROM
  l: 0 no echo, 1 echo, 2 Machine I/O
  c: copy from <adx> to <val>
? - help
>
```

On a unit with a corrupt or blank configuration the default-operating mode is 38400 baud with local echo enabled. The local echo option repeats every character received so that the user can see what they are typing.

The status of the non-volatile storage can be determined by the status LED on the RS160D. It has two states:

1. Blinking approximately once a second
Normal operation, non-volatile storage valid.
2. Blinking rapidly, approximately four times a second
Non-volatile storage corrupt, or never programmed after erase.

Examples of commands:

When fresh programmed, the non-volatile store will be corrupt and light flash rapidly and the default baud rate is set to 38400. Change it to 19200:

```
>@0sb2    Set baud rate #3 (19200)
>@0sw     Write configuration to EEPROM user slot 0.
>@1gb     Reports stored baud rate (3).
>@1ab     Reports operating baud rate (4).
```

The actual baud rate is the old value, 38400, until the unit has been power-cycled. The current baud rate is the programmed value. Reset the unit to load the new baud rate.

Normally, the RS160D interface prints information in response to user input. However, for most menu items (not @ registers), an optional repeat modifier may be specified to cause the RS160D to periodically print out information. The repeat modifier is just a number after the single character command. The number is the repetitions per second.

Internal Register Summary

Function	Lower	Upper	Default	Applies to	Notes
Servo					
B Brake	0	31	31	CH 0-2	0-100% braking at zero drive only.
c Copy values				Global	Funky: just copy servos
d Position Error Dead band	-255	255	0	CH 0-2	
D Velocity Error Gain	-32768	32768	0	CH 0-2	11.5 binary fraction:
e Position (encoder)	-2.00E+09	2.00E+09	0	CH 0-2	32 bit number
E Back-EMF factor	-32768	32768	0	CH 0-2	Used to estimate torque 12.4 Number; Multiplier for Normalized R/C value used as set points for various servo modes
F Input Factor	-32,000	32,000	8	CH 0-2	11.5 binary fraction:
I Integral Error Gain	-32768	32768	0	CH 0-2	Serial, Radio, Analog, or Step/Dir
J Input Select	0	3	0	CH 0-2	Encoder/Analog
J Feedback Select	0	1	0	CH 0-2	Not Implemented (yet)
L Position Limit	-2.00E+09	2.00E+09	0	CH 0-2	Minimum PWM drive to move output (De-dead band)
M Minimum Drive	-255	255	0	CH 0-2	0 - Off, PWM, Torque, Velocity, Winch, Position, AltWinch, SpinMode1, SpinMode2, Relay
m Mode	0	6	1	CH 0-2	Input to Position control loop
p Position Set point	-2.00E+09	2.00E+09	0	CH 0-2	11.5
P Position Error Gain	-32768	32768	0	CH 0-2	Loop rate in milliseconds, 0 = off
r Servo loop rate	0	255	10	CH 0-2	0-10 sec by .1 sec; Time to slew from -100% to 100% power
s Power Slew	0	100	0	CH 0-2	Input to Torque control loop
t Torque Set point	-255	255	0	CH 0-2	0-100% pwm.
T Torque Limit	-255	255	0	CH 0-2	In Encoder Counts (position error dead band for Step/Dir interface)
u Unit amount for manual move	-32768	32768	0	CH 0-2	In Encoder Counts
U Unit amount for minimum move.	-32768	32768	0	CH 0-2	Input to Velocity control loop
v Velocity Set point	-32768	32768	0	CH 0-2	Encoder counts/loop
V Velocity Limit	-32768	32768	0	CH 0-2	
Radio					
C Input Curve	0	31		Global?	
i Input Dead band	0	63		RC 0-3	+/- uSeconds around zero
n Low Limit	850	2150		RC 0-3	R/C Pulse width
N Upper Limit	850	2150		RC 0-3	R/C Pulse width
x Mixing	0	1		Global	Left/Right Off, On.
Misc					
b Baud Rate	0	3		Global	4800, 9600, 19200 and 38400
f Temperature Protection	0	1		Global	Volatile, enabled after reset.

	Function	Lower	Upper	Default	Applies to	Notes
*	Enter Boot-loader	n.a.	n.a.	n.a.	n.a.	Not implemented
I	User Interface Mode	0	2	n.a.	Global	no echo, echo, machine mode
Q	Compatible Preset	0	1	n.a.	Global	R/C PWM mode, straight or mixed
w	Write/Load values to/from EEPROM	0	3	n.a.	Global	s = set, a = current slot, g = get slot

User Interface/Menu

- "Cal" Enter R/C Calibration mode
- @ Enter/Print register values
- d PWM Drive
- e Encoder count
- ESC Exit R/C Calibration mode
- i R/C input in uS
- l R/C input, Normalized
- p Print Parameters
- r Reset Servo (stop)
- S Streaming parameters
- t Temperature
- v Velocity (counts/loop)

Internal Register Description

The following is a summary of commands used to set and query internal registers of the RS160D. Most commands operate on channels and apply (or print) values. A few commands have no register value. Please reference **Customizations**, under **Factory Defaults**, above, for details of the register command format.

Brake (B)

Range: 0-31 representing 0% to 100% brake.
Default: 31

Only applies when output drive is neutral (0% drive) on channels 0, 1 and 2 (Left, Right and Auxiliary).

Baud Rate (b)

Range: 0-3 representing the following baud rates:
0. 4800
1. 9600
2. 19200
3. 38400
Default: 3 (38400)

Changes to baud rate take effect **after** the system is reset by a power cycle. Channel value must be 0, but is otherwise ignored. Remember to save new baud rate in User Memory with the 'w' register.

R/C Input Curve (C)

Range: 0-7
Default: 3

Selects an exponential curve to modify the R/C input signal. Curves are useful for greater control of simple power based robots. 0 represents a flat line and 7 represent's an aggressive curve.

Copy Parameters (c)

Range 0-3

Copies the contents of registers for channel N to Y. Example to copy parameters from the Left register bank to the Right:

@0sc1

Derivative (velocity) Gain (D)

Range: 0-1023
Default: 0

Derivative gain is an 5.5 binary number that determines how strongly the servo attempts to maintain a velocity setpoint.

See **Tuning Servos**, below, for more information about this value.

Error Dead Band (d)

Range: 0-255

Default: 0

Back-EMF Factor (E)

Range: 0-255

Default: 0

Back-EMF is used to estimate the torque. The back-EMF factor is calculated by dividing 8196 by the maximum velocity at 100% drive (255). This is just an estimate as many PMDC motors have non-neutral timing and thus different back-EMF factors in reverse. If your motor has non-neutral timing, just take the average between forward and reverse velocity (ticks/period)

This factor can also be used to compensate for friction. The way to do this is to set the servo into the Torque mode with a torque set point of zero. Then adjust the Back-EMF gain until the system feels frictionless. When too large, the output, when disturbed, will accelerate. If too low, it will slow down and stop. When just right it will continue in the same direction and speed indefinitely (e.g. "frictionless"). Make sure you test at fairly high velocities as the back-EMF values are inaccurate at low velocities.

Typical back-EMF factors are in the 8-30 range.

Encoder value (e)

Range: +/- 2 billion

Default: 0

This register contains the current encoder value, often thought of as **position**. By writing this register the position can be set to any value. The value in this register will be restored when loading user parameters. So, if you want the default, boot value to be zero, then zero this register *before* saving user parameters.

The RS160D encoder input implements a 2X quadrature decoder. One multiplies the encoder slot count (e.g. 64) by 2 to determine the total number of counts per revolution.

Input Factor (F)

Range:

Default: 0

The number multiplied by the selected input method (R/C or Analog input) to generate the appropriate control value. This number is divided by 32 after the multiplication so fractional values may be specified. See Appendix B for more information on input methods.

Temperature Protection Override (f)

Range: 0 & 1

Default: 0

This register allows temporary override of temperature fold back function within the RS160D. When set to 1 fold back is disabled and full power can be delivered regardless of the heat-sink temperature of the power driver. This value is volatile, meaning it cannot be saved and will be reset to zero after each power cycle.

Integral Gain (I)

Range: +/- 32,000

Default: 0

Integral gain is used in the PID calculation for correcting velocity errors. See

See ***Tuning Servos***, below, for more information about this value.

R/C Input Dead Band (i)

Range: 0-255 uS

Default: 10 uS

R/C input dead-band is specified in microseconds. The specified value will be used +/- around zero. The default value is +/- 10 uS around 1500 uS.

Feedback Select (J)

Range:

0. Encoder

1. Analog Voltage (0-5v)

Default: 0 (Encoder)

The J registers selects the feedback method for the servo controller. Analog feedback is typically a 10-100k ohm linear potentiometer connected between ground and +5v. The encoder method uses standard, inexpensive, industrial quadrature encoders to determine direction and speed of rotation.

See **Appendix B** for more details on input and feedback methods.

Control Input Select (j)

Range:

0. Serial command

1. R/C input
2. Analog Voltage (0-5v)
3. Step & direction input

Default: 1, R/C input

See **Appendix B** for more details on input and feedback methods.

Local Echo Option (I)

Range:

0. No Echo
1. Echo typed characters.
2. Special Machine interface mode.

Default: 1, echo typed characters.

The serial interface includes a line editor that supports backspace and escape (cancel). The editor can optionally disable character echo for machine interface (where a computer simply sends commands, not expecting data returned). There is a third method that facilitates machine communications while echoing the entire command line AFTER it has been processed.

Besides echo & no-echo, there is a third mode that implements a machine friendly interface to the @ commands. This interface does not echo received characters. After processing the command the interface echo's the original string, with the '@' replaced with a special character and post-pended with data, if any. The special characters are:

1. '!' - Error response (i.e. didn't recognize the command)
2. '*' - Normal, Ok response (no data)
3. '#' - Normal, OK response, data follows.

The Set Local Echo command is used to enter this mode and it can be saved in EEPROM like other parameters. Specifically, the following will place the unit in the special interface mode:

```
>@0sl2
*0sl2
```

Note the effect is immediate (i.e. the response is the new acknowledge string), but the command still needs to be stored to be active after the next power up.

Example, Set Encoder value:

```
Send: @0se1234<cr>
Get: *se1234<cr>
```

Example, Get Actual Encoder Value:

```
Send: @0ae<cr>
Get: #0se1234<cr>
```

Example, Get encoder value from invalid address:

Send: @2ae<cr>

Get: !2ae<cr>

Minimum Drive (M)

Range: 0-255

Default: 0

Minimum drive specifies an amount of drive to add to the output in order to overcome drive train friction. See, ***Customizations***, above for more details.

Servo Mode (m)

Values:

0. Off
1. PWM
2. Torque
3. Velocity
4. Position Mode using winch (no back-drive)
5. Position Mode (position with back-drive)

Default: 0, off.

Servo mode selects the operation of the servo. A description of each mode can be found in ***Tuning Servos***, below.

A note about *Winch* position mode: when a worm gear drive is used for a servo transmission, the output cannot be back-driven. I.e. torque on the output shaft cannot be transmitted back to the servo motor. Winch drive recognizes this special case and resets the PID Integral error term when the drive reaches the position set point. Normally, the integral error term is needed to hold back-drivable servos in position once the set point has been achieved.

R/C Pulse High Limit (N)

Range: 0-32,000 uS

Default: 1950 uS

The R/C pulse limits are the calibrated values for +/- 100% input. Normal R/C pulse range is 1.0 to 2.0 mS, with 1.5ms as the zero value. By selecting alternate high and low values the range of -100% to 100% can be shifted and scaled. The default values are suitable for most off the shelf R/C gear.

Note: despite the large range of limits available, the RS160D will only recognize pulse width values between 850 and 2150 uS as valid.

R/C Pulse Low Limit (n)

Range: 0-32,000 uS

Default: 1050 uS

See ***R/C Pulse High Limit*** for description of register.

Proportional (Position) Gain (P)

Range: +/- 32000

Default: 0

The RS160D servo uses the **P** register to determine the correction needed for a given error between actual and commanded positions. This value Proportional Error Gain term in the PID calculation.

See ***Tuning Servos***, below, for more information about this value.

Position Set Point (p)

Range: 0- +/- 2 billion

Default: depends

Position set point is the value that the servo drives to when in position mode. It is in encoder counts (see ***Encoder***, above). The default value is equal to the default value of the encoder. If a non-zero value is stored for the Encoder, then that value will be used for the initial position value as well. The default behavior prevents uncontrolled servo movements when power cycling the RS160D.

Factory Preset (Q)

Values:

0. No mixing
1. Mixing enabled

Default: 0

The ***Factory Preset*** register resets all registers to a known default configuration. The optional value selects whether mixing is enabled or not. The default configuration is as follows:

- PWM output mode
- 50 Hz update rate (20 mS period).
- R/C input selected
- 1.050 to 1.950 ms R/C calibration range
- 1/10 second slew
- 100% brake at neutral stick position
- Mild #3 curve
- All other registers set to default values.

Note: The default setting for corrupt (or brand new) user storage is Q0.

Servo Update Rate (r)

Range: 0-255 mS

Default: 0 mS

This value sets the basic loop rate for the servo calculations. Most all other parameters and values depend upon this value. Values can range from 0 (off), to 1 (1 kHz) to 255 (about 1/4 Hz).

Power Slew Rate (s)

Range: 0-100

Default: 1

Power slew affects how fast the drive value can change. The value represents 1/10th of a second for -100% to 100% power change. The default value takes 1/10th second to slew the power from full forward to full reverse. Power slew rate only affect servo mode 1: PWM and requires an update rate of 50 Hz to work properly.

Torque Limit (T)

Range: 0-255

Default: 0

Torque Limit used in conjunction with Back-EMF factor (E) can fairly accurately limit the maximum current draw, and thus torque, of the drive motor. At stall, zero velocity, zero back-EMF, 100% drive (255) will produce maximum torque and current draw. Fractional drives will produce fractional torque and current draw. When the motor is rotating, the back-EMF counters the drive, reducing torque and current. In order to maintain constant torque (and current draw) over a wide range of velocities, it is necessary to add the drive value to the back-EMF value. As the velocity increases, the overall drive will increase to maintain the torque.

The torque limit sets how much *additional* drive is allowed above the back-EMF value. The additional amount divided by 255 is the fractional amount of the stall current (and torque) that will be generated.

An additional note: torque and rotational mass will determine acceleration and deceleration time for the servo. By limiting torque, one can control acceleration and deceleration of the servo. Or, one can limit maximum current draw, thus preventing circuit breakers from tripping.

Torque Set point (t)

Range: 0-255

Default: 0

The torque value used in servo Torque mode. In any other mode this value is either ignored, or continuously overwritten by the higher level servo algorithms (Velocity, to be exact).

Unit Amount Minimum Move (U)

Range: +/- 32,000
Default: 0

This register is in encoder counts and can be used to smooth rapid small input changes by preventing a move from starting until a certain absolute change has been noted in the set point. This register only affects position servo modes.

Unit Amount Manual Move (u)

Range: +/- 32,000
Default: 0

The RS160D has inputs that can be used to manually slew the servo position without changing any internal parameters or set points. This is useful for setting “zero” points on servo controlled equipment as the RS160D does not have limit or zero switch inputs. Refer to **Appendix C** for a wiring diagram for manual move inputs.

Manual move only works in mode 0 (safety reasons). When a manual move switch is closed the RS160D temporarily switches to position mode and makes the move. A short while after the move the RS160D returns to mode 0 (off). Closing the manual move switches in any other mode has no effect.

Velocity Limit (V)

Range: +/- 1023
Default: 0

The velocity limit controls how fast the RS160D moves the output to a new position set point. Velocity is in terms of encoder counts per servo update period.

Velocity Set point (v)

Range: +/- 1023
Default: 0

This register sets the velocity set point when in velocity servo mode. When in position modes, the position servo sets this value while moving to a new position. Setting this value in any mode other than position servo has no effect. It can be read at any time.

Write User Memory (w)

Range: 0-3
Default: 0

This command does not have a parameter. The channel number (0-3) is used to select one of four memory slots to store custom parameters. The last slot referenced (either written or recalled) will be used for initialization in future power cycles.

Channel Mixing (x)

Values:

2. No mixing
3. Mixing enabled

Default: 0, No mixing.

Channel mixing is typically used in R/C control situation where a single stick is used for throttle and steering. When enabled, mixing uses the LEFT channel for throttle and the RIGHT channel for steering.

Menu Items

- a{c#}<cr>
Displays analog channel inputs 0-7. This command is not too useful since only channels 6 & 7 are used and are displayed better with the 't' command. {c#} is a modifier. If you enter "a5c<cr>" the analog values will be continuously displayed five times per second..
- d{c#}<cr>
Displays output drive value. The servo uses an eight-bit PWM hardware for 255 levels of output. So, 0 to 255 represents 0-100%. Negative numbers are reverse power. Again, the "c#" modifies the command for continuous output.
- E{c#}<cr>
Displays encoder values. Useful for checking operation of the encoder and verifying that the wiring is correct. Positive PWM shaft rotation needs to produce positive encoder changes.
- p<cr>
Print out a short summary of all servo parameters and current operating conditions. See section on tuning for more details.
- P<cr>
Print out a summary of the R/C parameters and current operating conditions.
- S{c#}<cr>
Displays streamlined parameters. The parameters include the following in the order shown.
\$<Left Mode> <Right Mode> <Left Encoder> <Right Encoder> <Left Velocity> <Right Velocity> <Left Torque> <Right Torque> <Left Drive> <Right Drive> <HS1 Temp> <HS2 Temp> <Left over current> <Right Over current>
<CR>
Note: the left and right over current values are latched upon the over current event and are not cleared until printed with the next S command.
- T{c#}<cr>
Print out the current temperature of the power driver heat sink. The RS160D

starts to fold back the power levels at 60 deg C and fully shuts off the driver above 130 deg C. The fan will turn on at temperatures over 40 deg. C.

- $V\{c\#}\langle cr\rangle$
Displays the current velocity. Velocity is the change in encoder value per unit time. See tuning, below, for more details.
- $@\langle\dots\rangle$
Machine commands used to control the servo.

Output Drive values

The RS160D uses 8 bit PWM hardware. It uses values from 0 to 255 to represent 0 - 100% drive. Drive can also be in reverse. Hence, drive (PWM) values are specified from -255 to 255.

Control Period

Control cycle period (r) is a whole number from 0 to 255 that is a multiplier of the basic 1 millisecond system tick rate, or 0 to .255 second period. When 0 the servo mechanism is disabled and the output allowed to coast.

Position & Encoder values

Position is in terms of the encoder counts. The encoder resolution * 2 gives the total number of counts per revolution.

Velocity

Velocity is in terms of encoder counts/loop period. It depends upon the loop rate and the encoder resolution. For example with 120 rpm, no load maximum shaft speed and an encoder resolution of 100ppr, quadrature decoding, a 10 ms loop rate gives the maximum of $(120\text{rpm}/60) * (100\text{cpr} * 2) * 10\text{ms} = 4$. This is not useful, so the loop rate needs to be stretched out to 100ms for a maximum velocity of 40. It is an engineering decision whether to increase the encoder resolution or increase the loop period in order to get reasonable range of velocity. In this example whether to increase the period, or increase the Pulses per Revolution (ppr) of the encoder would be determined by the rotational mass of the system: light systems that react fast need fast loop rates, thus higher ppr. Large slow to accelerate systems might get away with a longer loop rate.

Torque

Torque Set point is a dimensionless number from 0-255, with 0 = no torque and 255 being 100% at stall. It is determined by the internal 8-bit PWM hardware.

Tuning, discovering servo PID Gain values

Start with zero for all parameters before enabling the servo. Then precede through the various servo modes to adjust each gain value. In the instructions that follow, the commands are referenced by their register name. A full command must be used to set the value of the register.

Off Mode (0):

Zero all gain parameters (P, D, I and B) and command values (v, V, p, t and T)

PWM Mode (1):

1. Set mode (m) to 1
2. Set torque set point (t) to 255 and measure velocity.
3. Adjust loop rate (r) for a maximum velocity between 50 and 1023. The actual best value will depend upon the resolution of the encoders and the mass of the drive train and torque capabilities of the motor. Some experimentation may be required.
4. Repeat for a torque set point of -255.
5. Set the back EMF gain (B) to 8196 divided by the average max velocity e.g. $(8196 * 2) / (V \text{ forward} + V \text{ reverse})$.

Torque Mode (2):

Adjust Back EMF (B) gain until the unit feels frictionless. The motor should be easy to spin both forward and reverse. Most PMDC motors have different back-EMF constants for forward and reverse, so some compromise is needed. If it is difficult to tell, then simply leave it at the calculated value. Otherwise adjust the calculated value until the entire mechanism feels relatively frictionless. By increasing the calculated value of B friction within the mechanism can be partially compensated.

Be careful, too much *extra* Back EMF can cause instability in the servo operation. At low speeds slip-stick friction needs extra Back-EMF to overcome, but this becomes too much at higher speeds and can cause oscillations. It is better to use Minimum PWM value to compensate for low speed slip-stick friction.

Velocity Mode (3):

1. Set the torque set point (T) to maximum (255).
2. Adjust velocity gain (D) until shaft is difficult to turn, but does not oscillate. Usually 1/2 of the value that causes oscillations is pretty good.
3. Adjust Velocity Integral gain (I) until shaft becomes very stiff, but again without any oscillations. It should return to the zero position after any displacement.
4. Set the velocity SP (v) to some small value and verify that the motor turns slowly and smoothly. Some playing around with the D and I terms may be needed. If the system does not seem tight enough, experiment with faster loop rates. Adjust the previously discovered values by the change in loop rate (i.e. if 1/2 the period, then double the gains, etc.).

Position Mode (4):

1. Set velocity set point (v) to the maximum recorded in PWM mode.
2. Adjust position gain (P) so shaft is very stiff, but does not oscillate. Usually very small position gains are needed (i.e. 1-16).
3. Reduce velocity set point to whatever maximum is required.
4. Experiment with driving the system to various positions using both low and high velocity limits. Verify smooth, oscillation free operation for each condition.

Whenever modes are changed, various parameters may be reset. In particular, the Integral error term is reset and the encoder position is forced to the current position set point (if the new mode is position servo).

Upon boot, configuration parameters are read out and set (assuming no checksum error) and the encoder positions are initialized to the current set point. The servo-operating mode is always set to OFF. Changing from OFF to one of the various servo modes will cause the encoders to be reset to the current position set points.

Indicators and Outputs

Status LED

This LED winks once per valid channel per two-second period. With all four channels connected it appears like four rapid flashes and a long pause. When in calibration mode the LED flashes evenly without pause.

Temp LED

This LED is off under normal conditions and will start to flash as the temperature of the controller increases to the point of thermal power foldback. A faster the flash indicates a hotter temperature. Once the critical shutdown temp is reached the led will stay on until the temperature drops and the controller resumes operation.

COAST LED (Aux, Left & Right)

Illuminated (Red) indicates the controller has disconnected the power driver from the load. The load is coasting. Dark indicates the power driver connected to the load. This LED varies from fully illuminated to fully dark depending upon the position of the input signal and the BRAKE user adjustment.

FWD/REV LED (Aux, Left, Right)

Green = Forward, Yellow = Reverse. Dark = zero drive. The RS160D modulates the Coast signal to implement variable brake. When the power driver has zero drive and zero COAST (i.e. both LED's are dark) maximum braking is applied to the load.

Limitations and Warrantees

Robot-Solutions, LLC (robot-solutions.com) provides no warrantee of suitability or performance for any purpose for the RS160D. Use of the RS160D software and or hardware is with the understanding that any outcome whatsoever is at the users own risk. Robot-Solutions, LLC sole guarantee is that the software and hardware performs, to the best of our knowledge, in compliance with this document at the time it was shipped.

Support

For additional information and or support send an e-mail to:
<mailto:Support@Robot-Solutions.com>

General Guidelines

- Caution does need to be taken with the use of the RS160D as with any other motor controller. In rare cases where the motor controller fails, it can lock in the “ON” position with no ability to stop the motor that is being controlled. All users should utilize a safety disconnect to the main power to allow for the safe disconnect of the power.
- Never remove the power to the motor controller while the motor is running. This may damage the controller.
- While it was designed to withstand significant abuse, normal static handling procedures should be observed.

Copyright ©2005 Robot Solutions, LLC
Copyright©2003-2005 Barello.net, Inc.

Author: David Moeller, Larry Barello
Contact info: David@Robot-Solutions.com
Larry@barello.net

Contact the author with problem reports or fixes, feature requests or additions and questions. They are welcomed and will be incorporated as time permits

Appendix A: System Software Updates

The RS160D includes a boot loader program to facilitate software updates via the RS232 port. No special programming hardware is required. The only requirement is a PC with a serial port. The procedure is as follows.

1. Connect the RS160D to the com1 port on the PC and verify the connection by using a terminal emulator to interact with the user menu.
2. Unzip the update software to the PC with the included Bootloader.zip file.
3. If necessary, copy the new software to be uploaded into the RS160D to that directory.
4. Open "My Computer" and browse to the directory where the file was unzipped.
5. Double click the cmdprompt.cmd program. This will bring up a DOS window.
6. Type the following command, "update RS160D.hex" substituting the new software file name where appropriate.
7. The program will start uploading, and you should see the status bars go to 100%.
8. When you see "avrdude done. Thank you!" exit the DOS window and the software should be loaded and ready to use.
9. If you need to use a different com port, edit the file "update.cmd" appropriately.

Appendix B: Input methods

Control Input Methods

The RS160D features a variety of control and feedback mechanisms. These mechanisms can be independently assigned to each channel. Thus, an R/C receiver can control a servo with an analog feedback, or a step & direction input can control the position of an encoder feedback servo. Some operating modes won't work properly with certain feedback mechanisms. For example, using analog feedback with a velocity servo as the analog feedback signal has mechanical and electrical limits.

When using analog or R/C input methods the input values must be transformed into values suitable for servo operation. This is done with the @f command. The register value is multiplied by the input value and then divided by 32 to obtain the results. The results are then applied to the selected servo set point.

Serial

Besides configuration setup, all servo set point parameters are accessible via the serial interface using @ commands. Note: depending upon servo mode, some set points are overwritten by the servo. For example, the position servo continuously updates the velocity set point to achieve the position goal. The serial interface can be used to examine the current velocity set point, but not to modify it.

R/C control

Standard hobby radio control equipment or equipment that conforms to the R/C signaling standards can be used to input a +/- 1023 count signal. This value controls selected set point parameters with a conversion factor. A typical use implements a giant R/C servo: the R/C input controls a large servo motor with a potentiometer feedback for position.

The R/C signaling standard calls for 1.0 to 2.0ms pulse width with a 20ms repetition rate. The RS160D can correctly decode pulse widths from .850 to 2.150 ms and as fast as 300 Hz repetition rate, on each channel. The factory default calibration sets the +/- 100% value to 1.050 to 1.950 ms, respectively. The default values should be compatible with all off the shelf R/C gear. The RS160D includes a calibration method to adjust the default limits or the serial interface can directly set the +/-100% timing.

Analog Signal

Analog signals are 0-5v values that are converted into a +/-2047 count signal. See ***Feedback Methods***, below, for important information about analog signals.

Step & Direction

Step & Direction input simulates a stepper motor interface, commonly found on CNC machinery. Each step moves the input function one encoder count.

Feedback Input Methods

Encoder

Industry standard quadrature encoders using 2x decoders (i.e. the resolution is twice the slot count). There is no support for index marks or limit switches. The RS160D can support up to three channels of encoder with a maximum sustained encoder count rate of 100 kHz, shared by all channels. If two channels are active, both can count up to 50 kHz simultaneously. The wiring information for the RS160D connectors can be found here:

<http://www.usdigital.com/products/connect/5pin-finger-latching.shtml>

Analog Signal

Analog feedback signals are 0-5v converted into a +/- 2047 count value. The internal converter has only 1024 values. A digital filter used to reduce noise, produces a 4096 count intermediate value which supplies the feedback and control registers. This works reasonably well, **HOWEVER, NOTE WELL:** if the analog signal is very clean and noise free only 1024 distinct values can be detected. So, even though the system works with a +/- 2047 value, the control resolution is only +/- 511 counts.

Appendix C: Interface Wiring Information

Analog

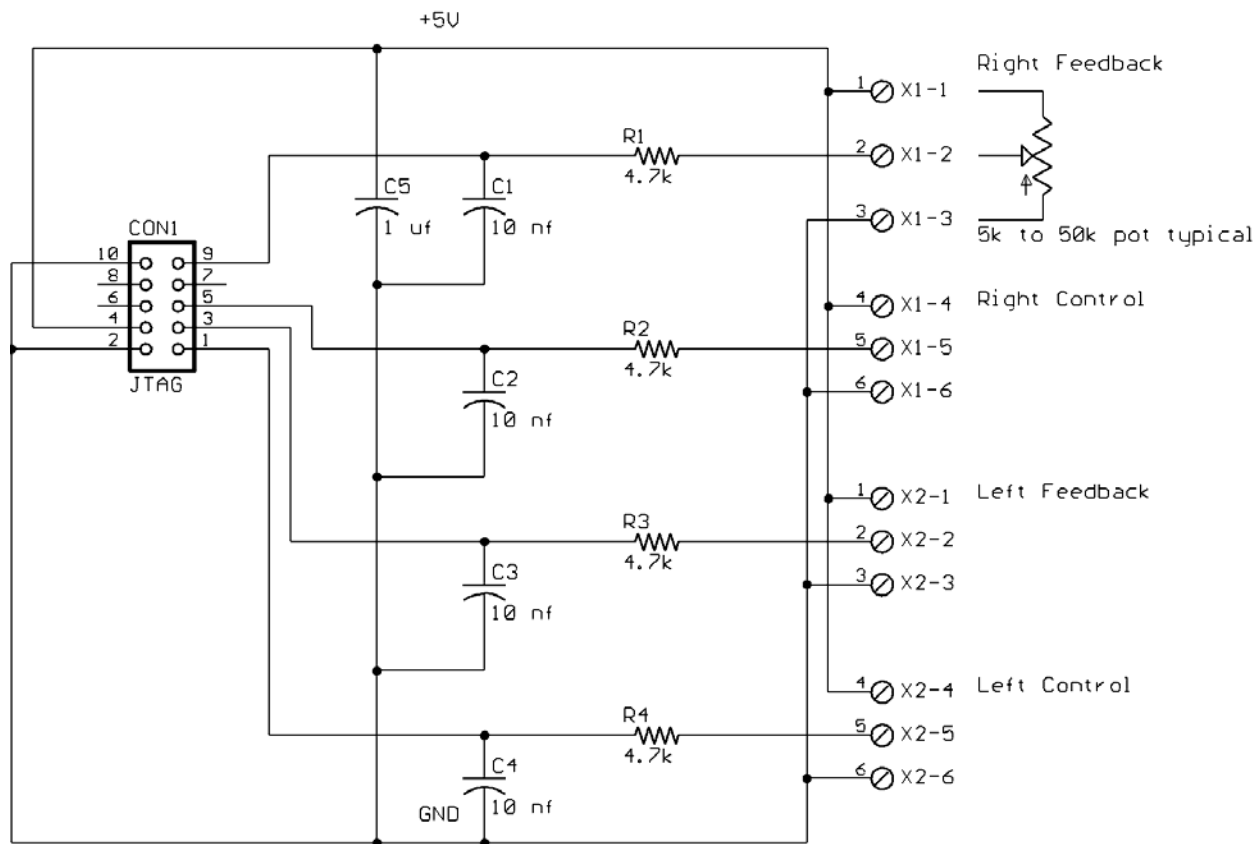

Analog signals are shared with the JTAG programming interface (non-latched 10 pin connector behind the AUX OSMC connector). The above interface can be used for mechanical (potentiometer) connections.

Other direct analog signals can be connected directly to the header using normal CMOS analog signal considerations. The +5v and ground supplies are regulated and filtered on the RS160D controller. A reasonable amount of current (50-200 ma.) may be drawn from these supplies to power off board electronics.

There are two more channels available for the AUX servo, but these signals are not physically available on the RS160D controller.

Step & Direction

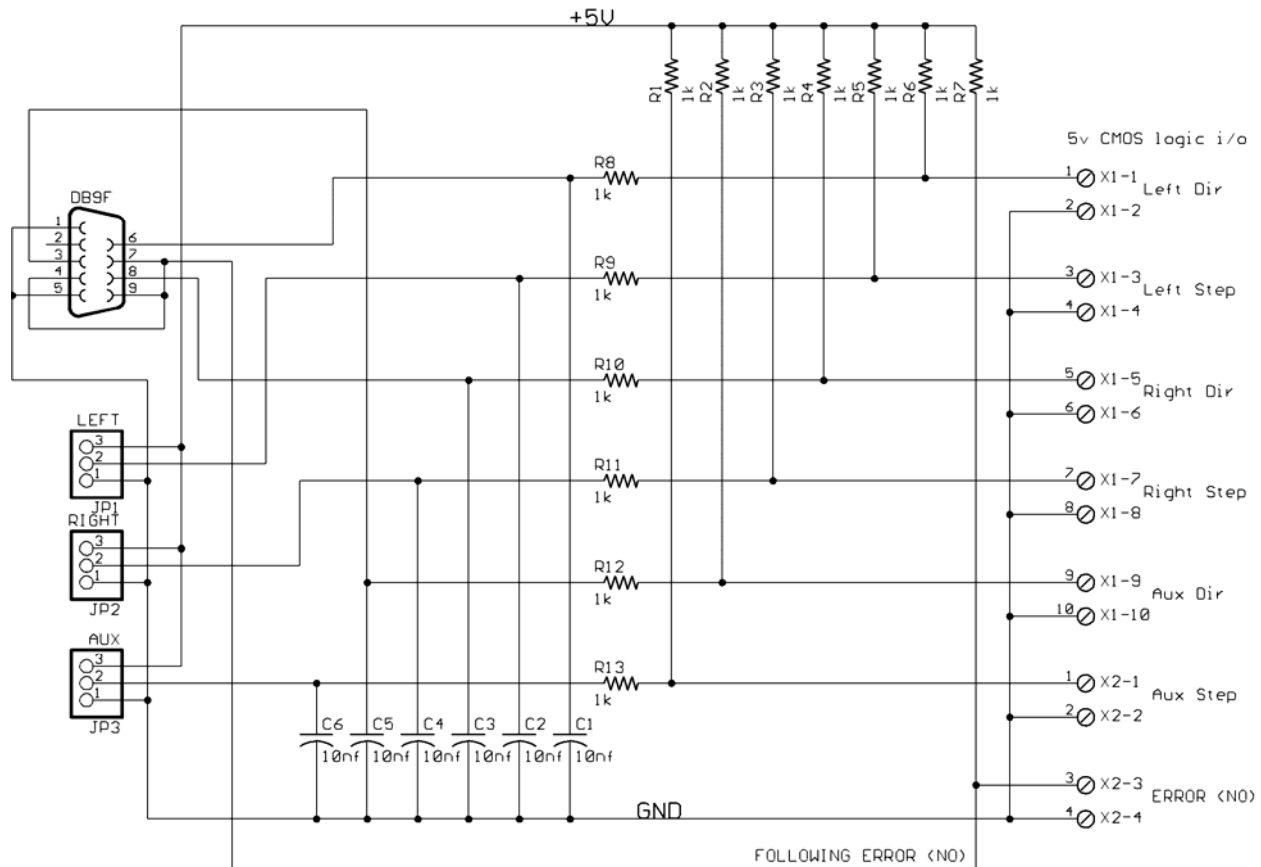

The CNC interface (Step and Direction) uses the Radio Control and Manual Move interface to supply the input signaling connections. The Radio Control connectors provide the high speed step input and the manual move interface provides the direction input and following error outputs for each channel.

The following error is a normally open (NO) CMOS output. The three channels are wired together to provide an overall NO error output. The output is not protected against voltage overloads: **DO NOT CONNECT THE OUTPUT TO A POWER SOURCE GREATER THAN 5.0 VOLTS OR YOU WILL DAMAGE/DESTROY THE RS160D.**

Incremental Encoder

The RS160D uses AMP MTA 5 pin Male sockets wired for US Digital Encoder standard cables. The pin-out matches the typical HEDS encoder electronics used in the US Digital encoders.



Pin	Description	Color (typical)
1	Ground	Brown or Black
2	NC	No Connection
3	A channel	Blue or White
4	+5VDC power	Orange or Red
5	B channel	Yellow or Brown

Figure 1 Typical encoder cable

MTA connectors are standard .1" spacing and suitable cable assemblies can be made from inexpensive socket parts from www.Jameco.com and others.

Manual Move

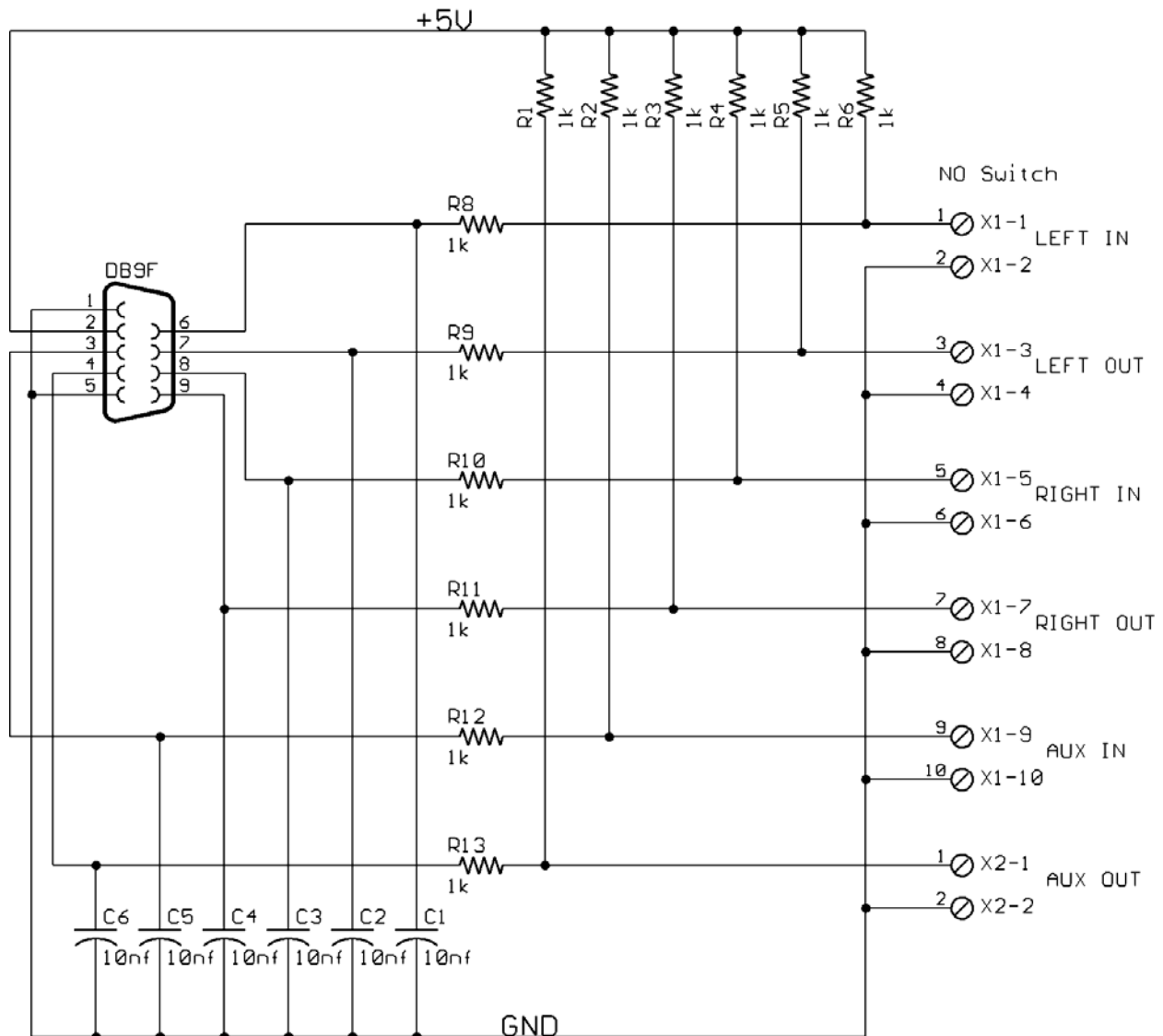

The manual move interface allows positioning of encoder based servos when the servo is disabled. The **Manual Move Unit Amount** (u) register controls how far the servo moves with each button press. The servo mode must be OFF and the servo tuning registers properly set for this function to work.

Appendix D: Example applications

Factory Default

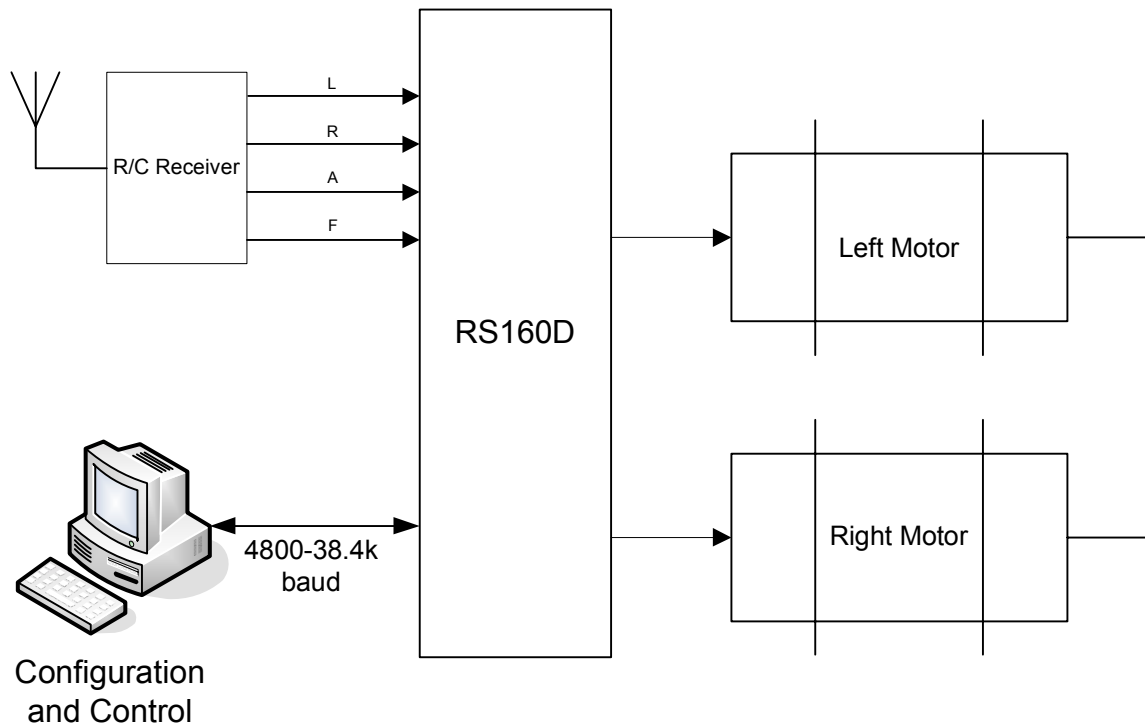

Factory default configuration supports traditional differential drive remote control robot operation (Combat robots, for example). The default configuration enables channel mixing so the LEFT input controls overall speed and the RIGHT input controls steering.

The configuration consol is not needed for operation but can be used to alter parameters to suit the users needs (input dead band, control curve, mixing).

Use the following commands to return to the factory default configuration:

@0sQ1

See **Factory Preset** under **Internal Register Descriptions**, for complete details.

Giant R/C Servo

By adding potentiometer feedback to motor output (typically a gearbox) the RS160D can serve as a two channel servo controller.

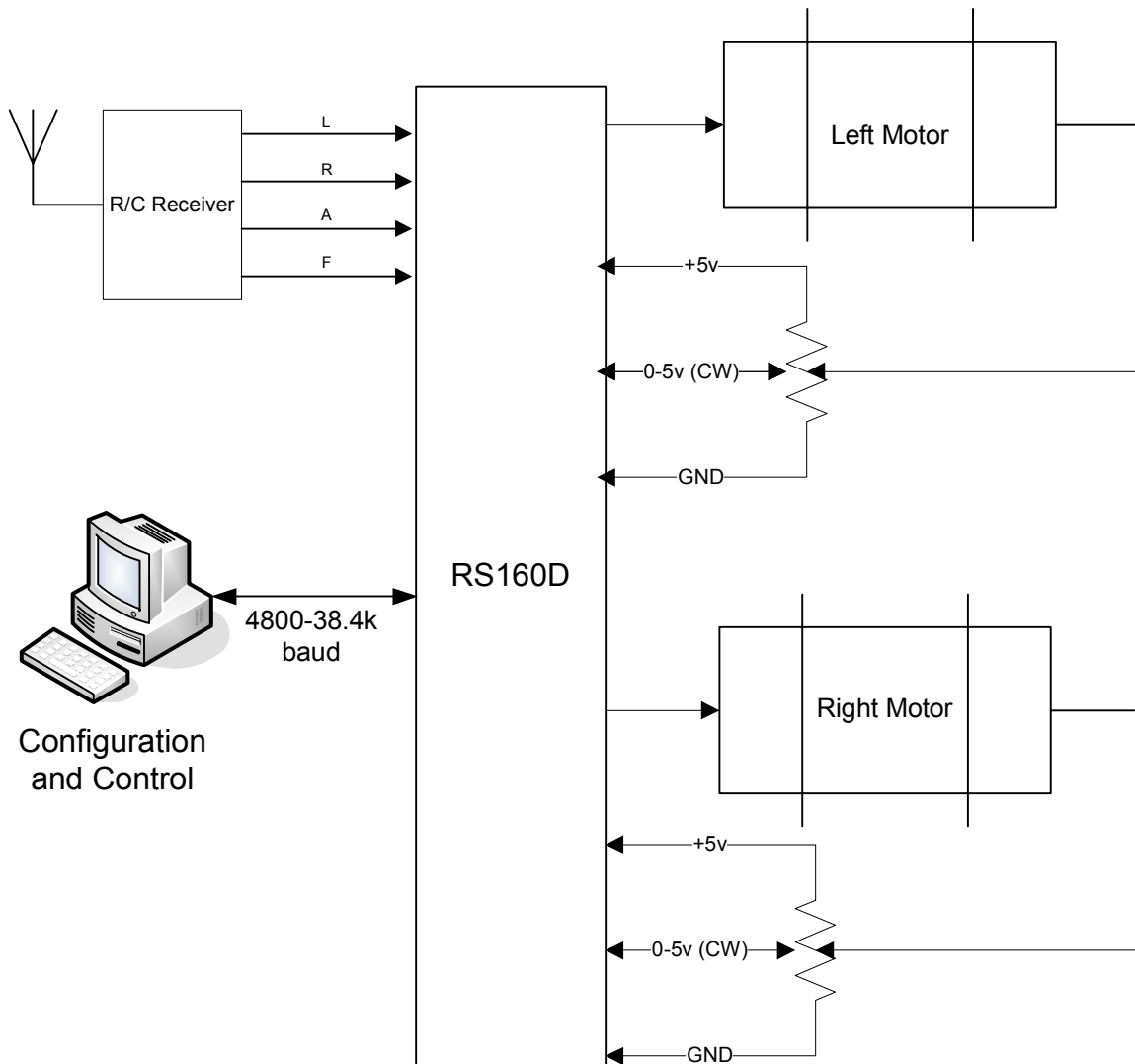

Set Up & Tuning

Because of the power available in the RS160D, it is recommended one use quality precision wire wound multi-turn potentiometers for the feedback mechanism. A typical unit would be a 5 turn, 10k pot (Bourns 3590S-02-103).

The parameters listed, below are general values that need to be modified for each particular situation. Read the section on servo tuning for more details. Certain values, like the Back-EMF value cannot be experimentally determined with potentiometer feedback, rather they need to be calculated. The same is true for reasonable velocity limits.

1. Reset factory defaults with no mixing: **@0sQ0**

2. Verify that forward stick movement causes an increase in analog feedback voltage. I.e. that positive drive output matches positive feedback.
3. Set the operating mode to OFF: **@0sm0**
4. Select the analog feedback mechanism: **@0sJ1**
5. Set the Input Factor (F) to 32: **@0sF32**
6. Set the torque limit to 64 (1/4 power) **@0sT64**
7. Set the velocity limit to 40 (about 2 seconds travel): **@0sV40**
8. Set the velocity gain to 128 **@0sD128**
9. Set the position gain to 16 **@0sP16**
10. Save the settings: **@0sw**

Now the servo is set up in a fairly safe mode. Be ready to turn power off quickly in case something isn't set up properly.

11. Move servo output close to the center position (of the feedback pot)
12. Enable position servo mode: **@0sm5**

At this point the servo should move (or not) towards center stick position. Test it out by moving the stick gently forward and back. The servo should track stick movement. If the servo starts to move, accelerate and race off in one direction, quickly turn off power! Either the motor or the feedback potentiometer is connected in reverse; fix this problem and try again. Because the servo mode was not saved the RS160D will power up in a safe mode allowing changes.

A complete description of parameters and tuning are beyond this users guide. Here are a few notes on improvements that can be made to the parameters:

1. The torque limit was set to ¼ the maximum.
2. The velocity limit was set for roughly a 2 second time for the servo to traverse from -100% to 100% position (+/- 2047 counts, 20 ms loop time, 2 seconds; $4094 * 2 * .02 = 40$)
3. The input factor was set so full stick travel (+/- 1000 counts) only requested +/- 1000 on the position, or about ½ the possible travel.
4. Back-EMF is roughly 8192/max velocity of the feedback signal. The velocity is the number of encoder ticks/servo loop at maximum RPM. Knowing that the feedback signal has a range of 4096 and the default loop rate is 20ms, use the gear ratio to calculate the maximum velocity at maximum motor RPM and the back-EMF factor.
5. Depending upon power of the motor, inertia of the control system, a 50 Hz loop rate may be too slow. If the loop rate changes, then various parameters will change proportionally.

CNC (Stepper motor) servo

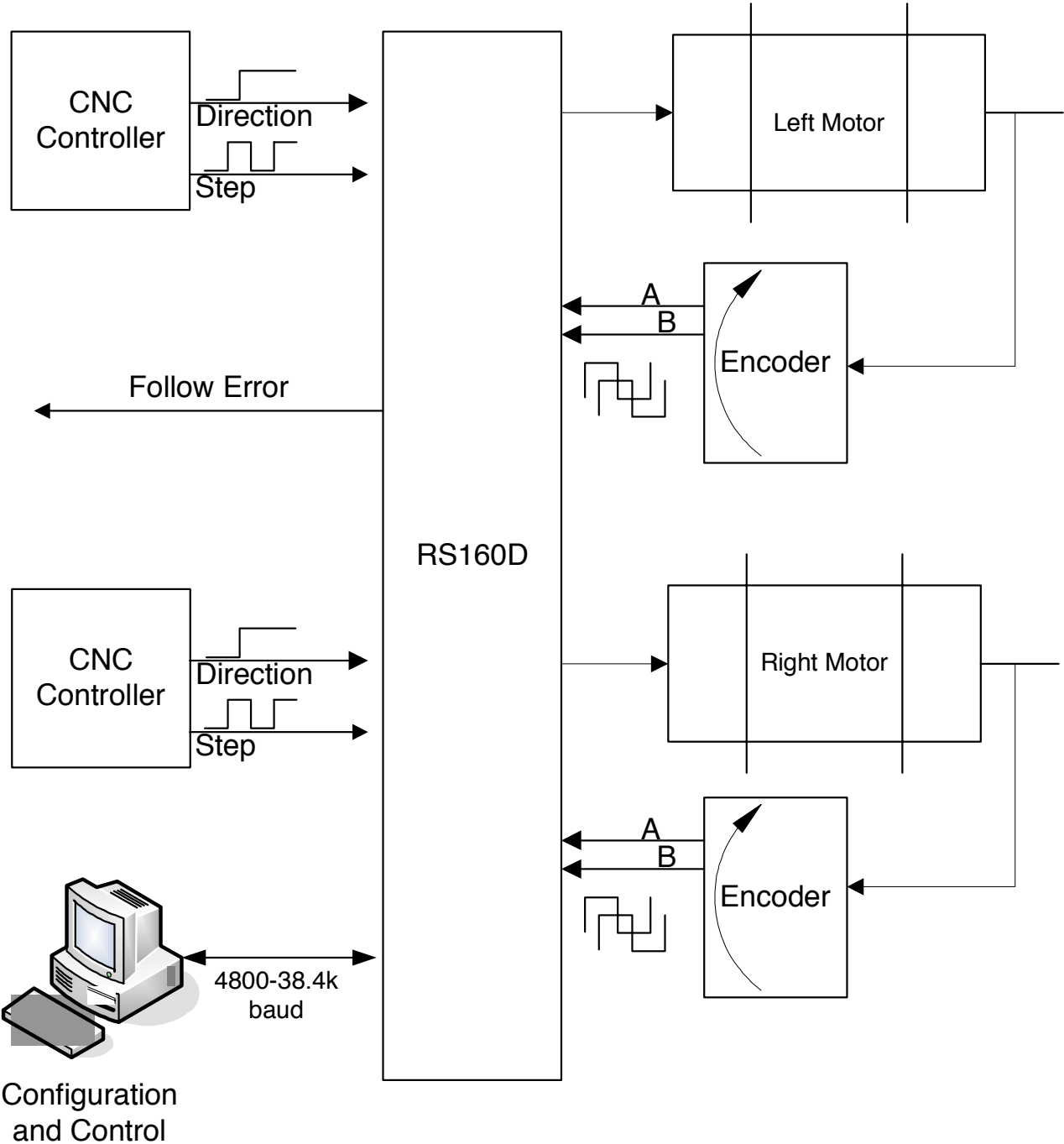

CNC Step control advances the position set point +/- one count for each 0 to 5v step input. 0v direction = reverse, 5v direction = forward. Three channels of CNC control are available on the RS160D with the addition of a third OSMC motor driver board.

Following error is a normally open CMOS output that is shorted to ground when the difference between the feedback position and the position set point exceed a fixed amount specified in the **U** register (unit amount, manual move). The following error output is only enabled when CNC is selected as the input mode.